

The Welding of Steel Road Bridges in the Past and Today

Abstract: The article discusses the construction of Europe's first welded bridge (over the river Śludwia in Maurzyce near Łowicz), design assumptions of the welded joints and the present condition of the welded joints made during the post-war repair of the bridge. For comparative purposes, the article presents today's welded solutions used in the footbridges of Most Szczytnicki (Szczytnicki Bridge) on the Stara Odra river arm in Wrocław. In addition, the article contains information related to the welding-based repair (if any) of structures of old riveted bridge structures.

Keywords: welded bridges, welding-based repair

DOI: [10.17729/ebis.2019.6/1](https://doi.org/10.17729/ebis.2019.6/1)

Introduction

In Maurzyce, near Łowicz, over the river Śludwia there is a welded truss bridge recognised as one of the finest technical accomplishments of the early decades of the 20th century. The structure in Maurzyce was Europe's first and world's third welded bridge. The first welded bridge (1927) was a small railway bridge built in Turtle Creek in the state of Pennsylvania (USA), designed and made as a plate girder structure. The second (also railway) welded bridge was constructed in Chicopee Falls (in 1928) in the state of Massachusetts (USA). The second bridge was significantly larger than that in Turtle Creek and designed as a truss bridge. Both bridges were built by General Electric Co.

The creator of the Polish bridge on the river Śludwia was Professor Stefan Bryła (1886–1943),

one of the world's greatest authorities in the area of steel building engineering [1–6, 8–11, 13]. Another person who had significantly contributed to the creation of the bridge was Władysław Tryliński, a transport engineer, whose name, slightly transformed, until today has been used to refer to a hexagonal precast concrete unit as trylinka.

Primarily, only the stringers and crossbars of the bridge were designed as welded, whereas the "entire" bridge was planned as a riveted structure. However, engineer Wenczesław Poniż (orig. Venčeslav Poniž, a Polish citizen of Slovenian origin), supervised by Professor Bryła redesigned the structure to be welded entirely. As a result, the original weight of the structure expected to amount to 70 tons if riveted, was reduced to 56 tons. Professor Stefan Bryła's principal achievement in the area of steel

Zbigniew Mirski, Professor PhD (DSc) Habilitated, Eng. – Politechnika Wrocławska, Wydział Mechaniczny, Katedra Materiałoznawstwa, Wytrzymałości i Spawalnictwa /Wrocław University of Technology; Faculty of Mechanical Engineering; Division of Materials Science Welding and Strength of Materials/

Józef Rabiega, PhD (DSc) Eng. – Politechnika Wrocławska, Wydział Budownictwa lądowego i Wodnego; // Wrocław University of Technology; Faculty of Civil Engineering/

Zbigniew Fałek, MSc – Biuro Projektowo-Badawcze /Research and Design Bureau/ Mifa-Projekt in Oława

structures was paving the way (through his theoretical works) for welded structures. Soon, riveting was replaced with electric welding, which marked significant progress in the construction of bridges.

The construction and operation of the bridge

The construction of the bridge was commissioned to Towarzystwo Akcyjne K. Rudzki i S-ka /joint-stock company/ seated in Warsaw, which, at the beginning of 20th century, was responsible for all major bridge investments in Russia such as, among other things, Russia's largest railway bridge over the river Amur near Khabarovsk and, in the years 1904-1914, the Poniatowski Bridge over the river Vistula in Warsaw.

The bridge on the river was designed as the 1st class road bridge located along a Warsaw-Poznań national road. The bridge of the span in the clear amounted to 26 metres, its effective span amounted to 27 metres, the spacing between the main girders was 6.76 metres, whereas the functional width of the bridge floor amounted to 5.40 m. On both sides, the bridge span was provided with footbridges, each having a width of 1.50 metres. The main girders were truss beams with the straight lower flange and the parabolic upper flange. The flanges were made of plates, whereas the walls of the main flange were stiffened with angle plates (Fig. 1 and 2).

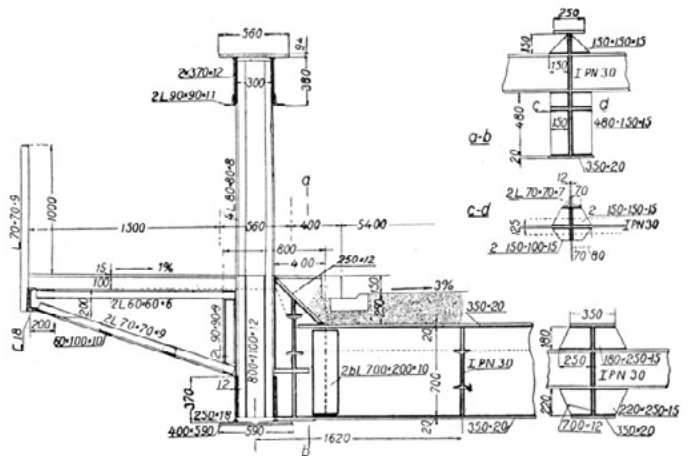

Fig. 2. Cross-section of the span of the bridge in Maurzyce [1]

Because of the fact that the bridge was Poland's first welded structure of this type, it was necessary to bring specialists and qualified welders from the Brussels-based company of Soudure Electrique Autogène. The Belgian specialists provided training to Polish welders and participated in the construction of the bridge.

The undertaking was not easy and met with reluctance as all of the Polish technical experts treated welded structures with suspicion. As the rumour of the day had it, the welded bridge only stood because it rested on the wooden scaffolding (Fig. 3), the dismantling of which would undoubtedly result in the collapse of the structure. The design engineers were sceptical about the new technology unknown to them then.

One of many outspoken opponents criticising the use of welding methods in bridge building was Professor Andrzej Pszenicki (1869–1941), a specialist in steel structures and the author of many designs of riveted railway and road bridges in Russia and Poland. Students of architecture at the Warsaw University of Technology would circulate a popular anecdote about a dispute between Andrzej Pszenicki and Stefan Bryła. Professor Pszenicki used to present to his students the difference between the traditional riveting and the modern welding in relation to the joining of metal elements by saying that (...) *riveting is like sewing, whereas welding is like gluing. Would you prefer a garment that has been sewn or the one that has been glued?* At the same time, in Germany, sceptics

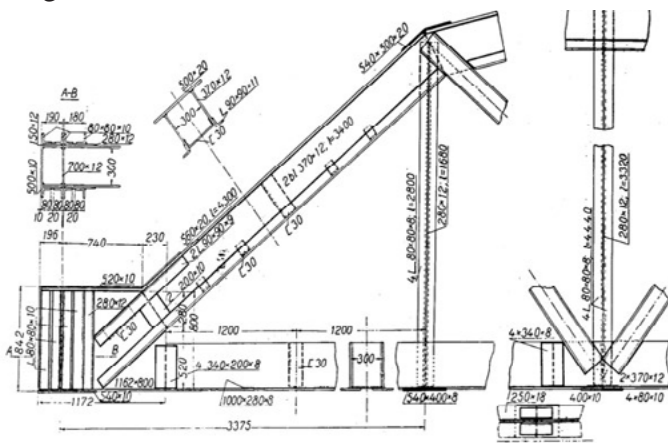

Fig. 1. Side view of the structure of the truss girder of the main span of the bridge in Maurzyce [1]

claimed that *welding is fine, yet not welding is even better or that the best welded structure is the one that is weldless* [7].



Fig. 3. Wooden scaffolding under the span of the bridge over the Słudwia river in Maurzyce [13]

The bridge took only 250 days to build, requiring the labour of only three welders. The test loading of the bridge took place between 9 and 12 August 1929. The span was loaded across the entire width and along the entire length of the bridge floor by depositing an 80 cm thick layer of sand. The constant deflection of the girders amounted to 1.8 mm. The tests did not reveal any distortion of the base material and areas subjected to electric welding. The dynamic load, exerted by means of a 16 ton heavy moving steamroller resulted in the deflection of the girder on the upstream of the bridge amounting to 1.7 mm and that on the downstream side of the bridge amounting to 1.4 mm. The above-presented results were consistent with those calculated by Professor S. Bryła.

The bridge, commissioned in 1929, was in operation until the outbreak of World War 2. At the second stage of the battle of Bzura (13–15 September 1939), the troops of the “Poznań” army when retreating towards Warsaw blew up the bridge support shoes on the right bank of the river and, consequently, also destroyed extreme segments of the upper and lower flanges so that the entire bridge structure on this side fell into the river with the opposite side of the bridge remaining on its bearings (Fig. 4).

In 1941, the bridge was lifted, repaired and put into operation. During the retreat in 1945, German troops destroyed the bridge in the

same manner as that described above, yet by blowing up the bridge support shoes on the left bank of the river. The bridge was lifted and repaired in 1946.



Fig. 4. Bridge damaged during the defence war in 1939 [13]

In 1977, the bridge was moved upstream by 25 metres, where, until the construction of a new bridge, it was used as a detour bridge. Upon the opening of the new bridge, the old bridge was closed down and left as a vintage bridge of technical and historical value.

Design assumptions and materials

Because of the lack of appropriate regulations concerning calculations of welded structures, the design was based on the regulations of the Ministry of Public Works of 1925 related to the 1st class bridge subjected to the loading of the bridge floor with a 6.0 m long and 20 ton heavy roller provided with an additional load in front of and behind (the roller) of 5.0 kN/m². The load assumed for the footbridges also amounted to 5.0 kN/m². Stresses present in the load-carrying structures were adopted in relation to the maximum values of loads. Values related to compressed bars were calculated using the buckling-related Tetmajer-Jasiński method.

In accordance with the design assumptions, the bridge should have been made of cast iron. This type of structural material was manufactured until approximately 1925. Following the aforesaid year, Polish steelworks (with German capital) located in Silesia started producing cast steel manufactured in accordance with

the requirements of German standards DIN 1050 and DIN 1612. The cast steels (named in the article accordance with the meaning of the term of steel used since 1925) were characterised by more favourable mechanical properties than cast iron, yet they did not contain alloying agents bonding nitrogen [3]. The final decision stated that the bridge would be made of cast ship steel grade 1GIIL. Table 1 presents the chemical composition of steel 1GIIL, whereas Table 2 presents the mechanical properties of steel 1GIIL confronted with the properties of steels used in the construction of welded bridges today.

Table 1. Chemical composition of steel 1GIIL [13] and today's steel grades used in the construction of bridges

Material	Chemical composition in % by weight (rest: Fe)					
	C	Mn	Si	P	S	Cu
1GIIL	0.11	0.47	0.023	0.030	0.060	0.20
S235J2G3	max. 0.17	max. 1.4	-	max. 0.025	max. 0.025	max. 0.55
S355J2G3	max. 0.2	1-1.5	0.2-0.5	0.04	0.04	0.30

Table 2. Steel products used in the past and today [5]

Steel type		R_m [MPa]	R_e [MPa]	A_5 [%]	k_r [MPa] ¹⁾
Cast ship steel	1GIIL	370-420	min. 240		98.1 ²⁾ 81.5 ³⁾
	S235J2G3	360-510	min. 235	26	
Today's steels	S355J2G3	490-30	min. 355	22	

¹⁾ design strength of steel 1GIIL:

$$k_r = 0.1(900+3L) = 98.10 \text{ MPa, where L stands for the effective span of beams}$$

²⁾ refers to the bridge span

³⁾ refers to bridge elements

Because of the fact that the regulations of the Ministry of Public Works of 9 November 1925, no. XIII-1386 did not yet contain regulations concerning welded joints, guidelines developed at a conference in the Belgian company of SEA (Soudure Electrique Autogène) specified that

electrode cores should be made of cast steel characterised by the following chemical composition of admixtures (in % by weight): C – 0.1, Mn – 0.25, Si – 0.023, P– 0.026, S – 0.05 and Cu – 0.23 (rest: Fe).

The above-named guidelines, adopted by the Ministry of Public Works, became world's first regulations concerned with the welding of steel structures. The Polish welding-related regulations preceded (by nearly a year) America's first welded structure-related regulations developed by McKibben.

All of the welded joints in the bridge were made using the MMA welding method and Tensilend type covered electrodes, supplied by the Arcos company and manufactured by SEA [9] (see Fig. 5). In study [9], the author does not specify explicitly the type and composition of the coating of the electrodes used during the construction. However, the author writes that *from among Belgian electrodes made by La Soudure Electrique Autogène, the Tensilend type electrode is the best for iron structures. The electrode enables the obtainment of joints characterised by high tensile strength and bending strength as well as by high impact strength and shock resistance. The average strength amounts to 450 MPa, whereas elongation is restricted within the range of 18% to 20%. The above-named covered electrodes were provided with a thick coating.*

In addition, study [2] informs that: *in iron building and bridge structures, riveting can only be replaced with arc welding, performed using appropriate metal electrodes having a diameter restricted within the range of 2 mm to 6 mm and a length restricted within the range of 350 mm to 450 mm, covered with special material, the primary role of which is to prevent the oxidation of the metal...*

Welding current was drawn from a generator (powered by locomobile) and transformed into welding parameters by a set of one-phase (Arcos). The welding current amounted to 180 A, whereas the electric arc voltage was 20 V.

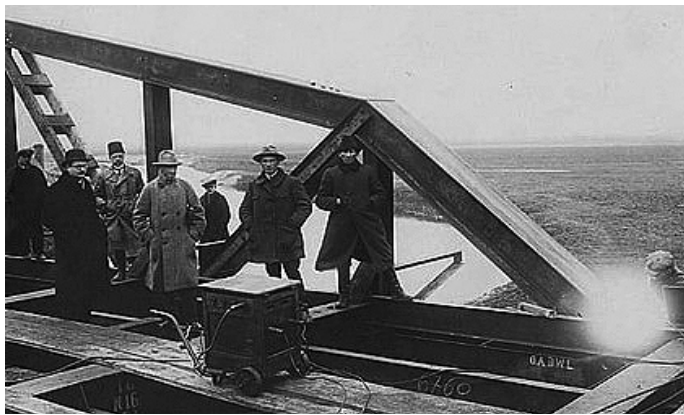

Fig. 5. Welding of a truss shoe; Professor S. Bryła (second from the left, wearing glasses) [13]

Presently, there are no equivalents to electrodes used in the welding of bridge elements in the 1920s. Today, the outdoor manual welding of field welds is performed using low-hydrogen electrodes, particularly when welding steel S355 and when making root runs during the welding of steel S235 and S275 (characterised by high toughness, even at a temperature of -50°C).

Tests of welded joints and welder qualification tests

The electrodes used for the making of the welded joints in the bridge over the river Słudwia were subjected to the following tests:

- tensile tests of welded joints,
- bend test of butt joints,
- weld elongation.

The permissible value of stress adopted during weld-related strength tests amounted to $k_r = 70 \text{ MPa}$.

Figure 6 presents specimens for static tensile tests: (a) specimens used in the past and

(b) specimens used today. Figure 7 presents the bending of the specimens, whereas Figure 8 presents stages of the preparation of a specimen for a weld elongation test.

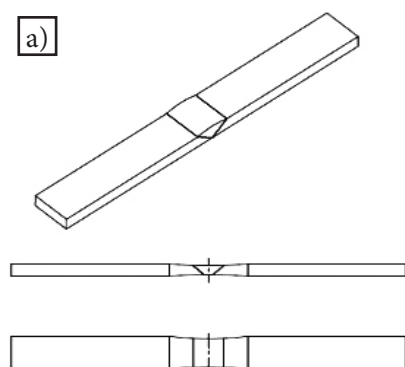
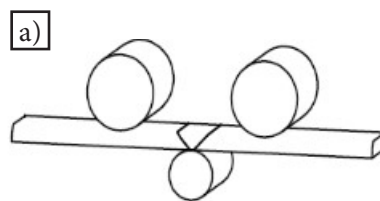

Fig. 6. Stages of the preparation of a specimen used in tensile tests of butt welded joints (a), present specimens (b)



qualification specimens to be subjected to bending tests (o) and shearing tests (o).



Fig. 7. Specimen in the bending test of butt welded joints, reverse system of bending probes (a), present-day technological bend test (b)

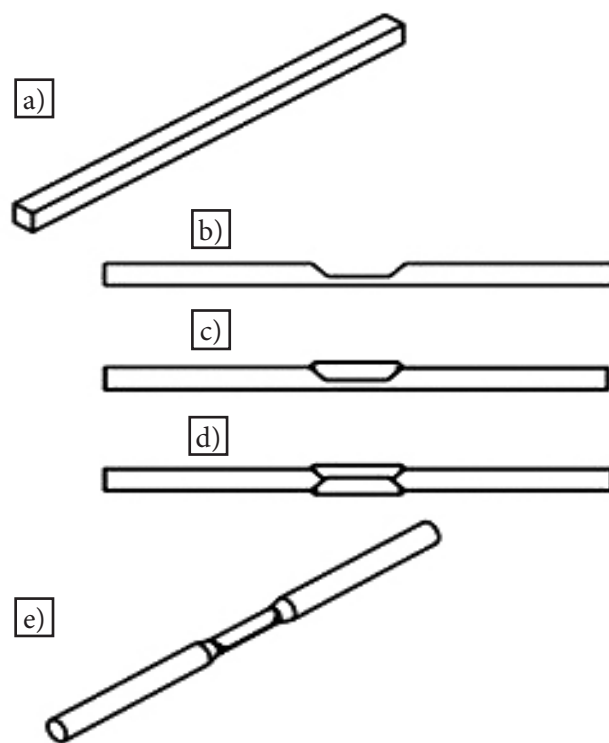
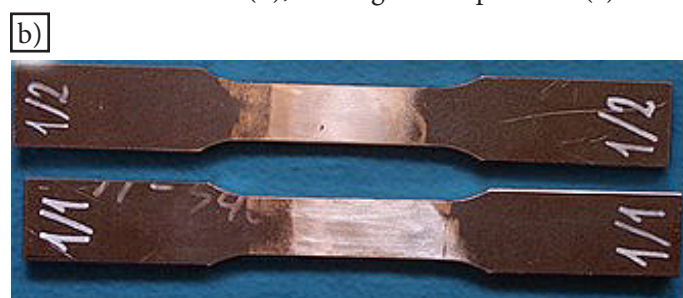

Fig. 8. Stages of the preparation of specimens used in the elongation of the weld in the static tensile test: cutting out the material (a), milling of the seat and the position of weld no. 1 (b, c), milling of the seat and the position of weld no. 2 (d), turning of the specimen (e)



The employment of a given welder depended on the positive result of a related test. Another requirement related to welders was concerned with their experience of welding with recommended electrodes in order to obtain the best possible results during welding works.

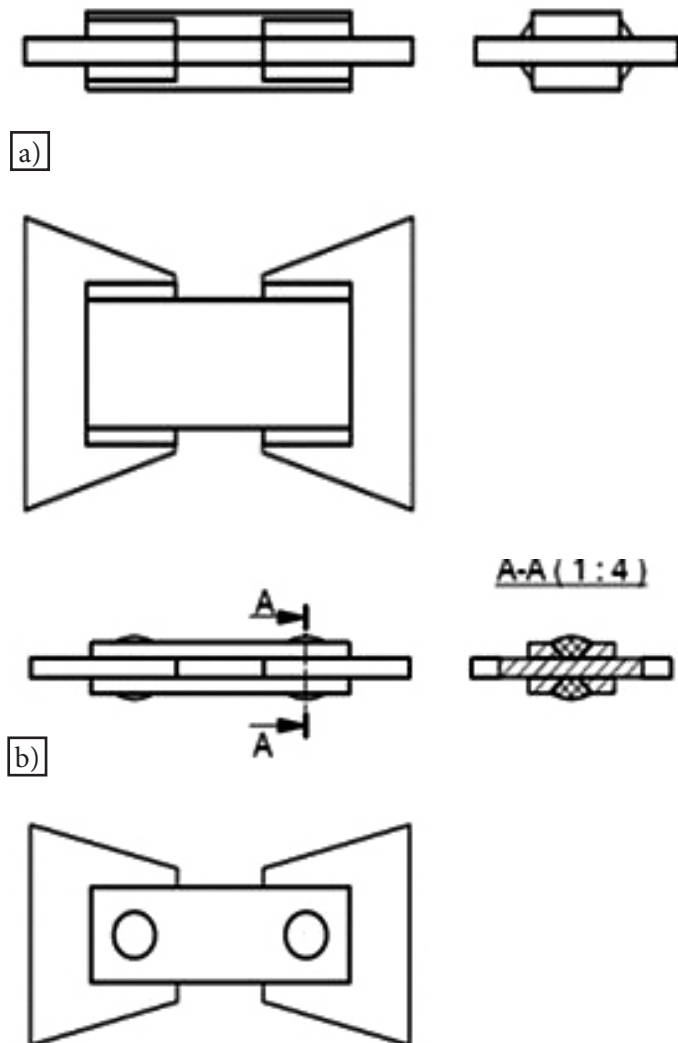

Fig. 9. Stages of the preparation of specimens used in the shearing test of welded joints: fillet welds (a) and plug welds (b)

Design of bridge structures in accordance with Eurocodes

Eurocodes are collections of European Norms applied in the design of building structures. The design of steel structures is addressed in the six primary standards of Eurocode 3.

Material and welding-related requirements to be observed in the construction of bridges are contained in PN-EN 1993-2:2010 *Eurocode 3 – Design of steel structures – Part 2: Steel bridges*. The standard refers to structural steel

grades (included in European standards) and their scope of application in the construction of bridges. The standard also discusses primary mechanical and welding parameters of European steels and specifies structural and technological requirements concerning welded joints in new bridges.

Steel grades used in the construction of bridge structures today have to be characterised by appropriate ductility, weldability and brittle crack resistance. Values adopted as yield point characteristics (f_y) are nominal values specified in product-related standards $f_y = R_{eH}$, $f_u = R_m$ (R_{eH} , R_m in accordance with a given product-related standard) [13].

Recommended ductility-related conditions: $f_u/f_y \geq 1,10$, $A_5 \geq 15\%$, $\epsilon_u \geq 15\epsilon_y$ ($\epsilon_y = f_y/E$, where $E=210$ GPa according to Eurocode 3).

The above-presented conditions are satisfied by steels S235, S275, S355, S420 and S460.

Steel bridge structures designed in accordance with PN-EN 1993-2:2010 are governed by PN-EN 1090-2:2018-09 *Execution of steel and aluminium constructions – Part 2. Technical requirements for steel constructions*. The standard addresses all the most important aspects connected with the design, production control and technical requirements concerning the making of steel structures, including bridges, also by means of welding methods [14].

In one of the studies, Professor Antoni Biegus from the Department of Metal Structures at the Faculty of Civil Engineering of the Wrocław University of Technology wrote that *The welding of steels is a complex welding engineering process. For this reason, it is recommended that the design of a steel structure should be consulted in terms of technology with specialists in welding engineering* [15].

Comparison of the old and presently made welded joints

The Szczytnicki Bridge over the Stara Odra river arm in Wrocław was built in the years 1888-1889 as a three-span bridge structure. The bridge

deck width amounted to 7.50 m, whereas footbridges on both sides of the bridge were 2.50 m in width each. The above-presented dimensions soon appeared insufficient for the important city street of Fürstenstrasse (in Breslau) running over the bridge. As a result, the years 1933-1934 saw the reconstruction of the bridge, including the extension of its total width up to 22.30 m, where the bridge deck width amounted to 11.00 m. Another reconstruction, dictated by the poor technical condition of the structure was performed in the first decade of the 21st century. The aforesaid reconstruction involved the making of two steel structures parallel to the existing bridge and intended for pedestrian and bicycle traffic as well as for the development of the area (utilities). The load-carrying structure for footbridges was composed of plate girders of variable height and spans consistent with the previous spacing of the bridge supports.

Figure 10 presents the welded joints of the load-carrying structures of the bridge over the river Słudwia before and after WW2 and the welded joints of the footbridge on the Szczytnicki Bridge over the Stara Odra river arm in Wrocław, subjected to retrofit in the years 2006-2008.

Weldability of steel manufactured in the 1920s

The long-lasting operation of steel structures exposed to dynamic loads leads to unfavourable changes of mechanical properties. When assessing the reparability of such structures, the aspect of primary significance is metallurgical weldability. However, information based on the identification of carbon equivalent (related to the chemical composition of the material) and the thickness of elements to be welded is insufficient as steels made in the 1920s (and before) contained significant amounts of nitrogen, i.e. a decisive factor as regards the ageing of steel products. In addition, old steels may include segregated (particularly sulphide) impurities arranged in accordance with the steel



Fig. 10. Welded joints of load-carrying structures: the bridge over the river Słudwia in Maurzyce (a, c, e, g) and the footbridge on the Szczytnicki Bridge in Wrocław (b, d, f, h)

rolling direction. Materials affected by ageing are characterised by increased tensile strength R_m , yield point R_e and hardness HBW (present designation), but also by decreased plastic properties including relative elongation A , relative area reduction Z and toughness KCV.

In steels affected by ageing, welding may trigger unfavourable changes in the material, particularly in the heat affected zone. This phenomenon is particularly dangerous in relation

to load-carrying structures exposed to dynamic loads. It is forbidden to repair cranes loaded with external forces by means of welding methods. In such cases, the structure should be unloaded before a repair. Otherwise, a unit subjected to welding may develop uncontrolled welding stresses and a heat input may irreversibly distort the geometry of the structural system.

The assessment of the weldability of old riveted bridge structures requires the performance of the following tests of the steel [12]:

- chemical composition analysis,
- metallographic tests (along and across the rolling direction) and the Baumann test,
- tests of mechanical and technological properties.

Because of the significant possible liquation of impurities and the concentration of carbon, the analysis of the chemical composition only allows the approximate assessment of the steel. Because of this, many riveted structures exposed to loads cannot be repaired using welding methods. Repairs taken into consideration include joints of mechanical nature.

The foregoing was confirmed by specimens sampled from the railing on the upstream side of the bridge over the river Odra in Brzeg, built in 1920 [16].

The gravimetric method-based chemical

Table 3 presents the result of the chemical analysis of the steel, the results of hardness measurements as well as the value of carbon equivalent CEV.

Chemical elements	Chemical composition; % by weight (rest Fe)						
	C	Mn	Si	P	S	Cr	%N
Test element	0.05	0.16	0.09	0.095	0.02	0.02	traces
HV 10	CEV, %						
90 +/-4	0.13						

analysis revealed that, in terms of the chemical composition, the material of the element subjected to the tests corresponded to that of low-carbon cast steel. Figure 11 presents the microstructure of the steel. The ferritic microstructure of the steel was characterised by variously

sized grains as well as significant precipitates of slag and sulphides arranged pointwise and in bands, in accordance with the direction of the plastic working of the steel. The material did not reveal structural degradation.

The low-carbon steel (0.05 % by weight of C)

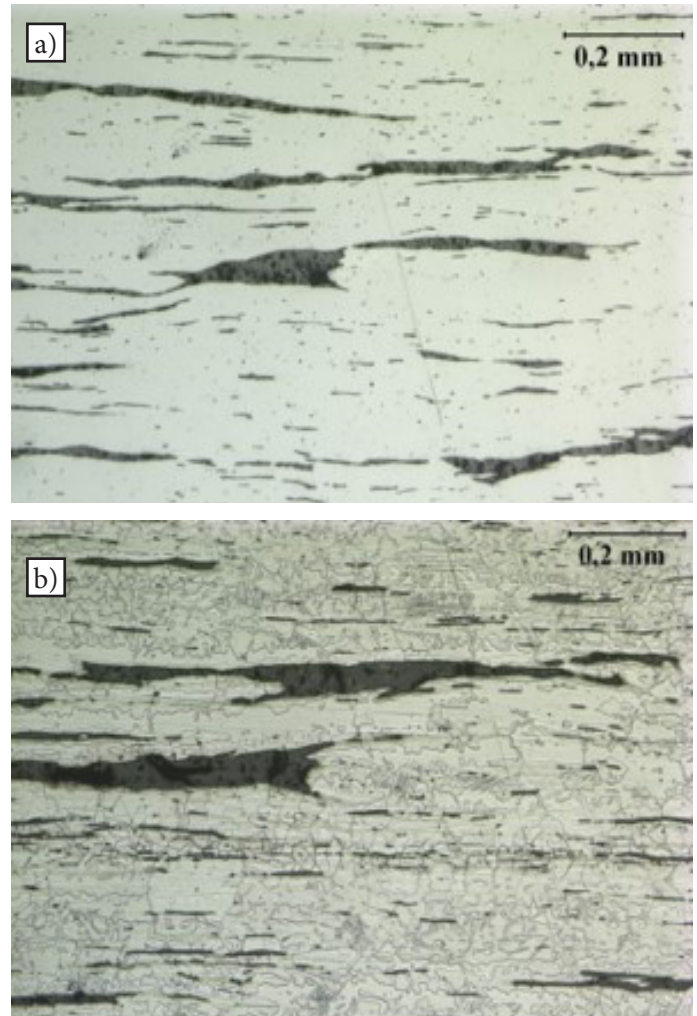

Fig. 11. Non-metallic inclusions in the form of slag and large sulphides arranged in bands in accordance with the direction of plastic working; unetched (a) and chemically etched in Nital (5 % HNO3) (b) [16]

was characterised by low hardness 90 HV 10 (+/-4) and a low carbon equivalent CEV (determining metallurgical weldability) of 0.13 %. In view of such material properties, the structure of the bridge should not have been repaired by welding.

Remembering the bridge and its creator

The bridge over the river Słudwia initiated the era of welded bridges in Europe. The progress of its construction was reported in many languages. In the Far East, the bridge attracted

attentions of Japanese designers and constructors. In German publications, the structure was referred to as *eine ausserordentliche Leistung* (extraordinary accomplishment). In 1936, Professor Gottwald Schaper (1873–1942), the pioneer in technologies enabling the welding of steel bridge structures in Germany referred to the bridge as *die weltbekannte Łowicz-Brücke* (world-famous Łowicz bridge). Soon after that, Professor Bryła became the vice-president of the International Commission for Bridges and Engineering Structures in Zurich.

Professor Stefan Bryła graduated from the Faculty of Civil Engineering at the Lvov University of Technology, where he also was granted his PhD (DSc) degree and habilitation. As early as at the age of 35, Stefan Bryła became a professor at the Bridge Construction Division of the aforesaid university to become a professor at the Faculty of Architecture at the Warsaw University of Technology in 1934. After the First World War Professor Bryła managed the Department of Bridges in the Ministry of Public Works. In November 1919, he was mobilisation commander during the defence of Lvov and in 1920 he volunteered for the war against the Bolshevik invasion. In 1928, Stefan Bryła became a Member of Parliament representing *Zjednoczenie Chrześcijańsko-Społeczne* (Christian and Social United Party), performing the function for three office terms. During the German Nazi occupation of Poland, he was the Head of the underground Faculty of Architecture of the Warsaw University of Technology, supervising several doctor's theses. Arrested with his family, Stefan Bryła was executed (shot dead) by German gendarmes on 3 December 1943 against the wall of the tram depot at ul. Puławska in Warsaw.

The figure of Professor Stefan Bryła should be remembered both by propagators of technology and all those entrusted with national heritage.

Summary

1. If confronted with present requirements, the quality of the welded joints in the bridge over the river Słudwia is relatively low, yet, taking into consideration the level of welding techniques in the late 1920s, the assessment should be positive.
2. Under current normative regulations, a significant number of welds contains unacceptable imperfections or defects [5]. However, the aforesaid imperfections were not formed when making the bridge but afterwards, i.e. during incompetently performed repairs and maintenance works of the bridge destroyed twice during in WW2.
3. Structural steel 1GIIIL used in the bridge was high quality steel, both in terms of metallurgical and mechanical properties.
4. Non-destructive testing methods applied when examining welded joints and the selection of welding personnel's qualifications were similar to those applied today.
5. The primary reason for the imperfections and defects of the welded joints was not atmospheric corrosion (as was suggested by many authors of studies concerning the bridge in Maurzyce) but the inept repair of damage performed after WW2. Corrosion damage was present, yet in adaptive elements of small cross-sections and repairable without intervening in the load-bearing structures of the bridge.
6. Interwar times saw the very dynamic development of welded structures in civil engineering. Building engineering progress was particularly noticeable in Germany (initiated by Professor Schaper) where hundreds of similar types of objects were put in place.

References

- [1] Bryła S.: Most na rzece Słudwi pod Łowiczem (Pierwszy most spawany elektrycznie w Europie). *Przegląd Techniczny*, 1929, no. 26, pp. 621–627.
- [2] Bryła S.: Spawanie żelaza w

- budownictwie i mostownictwie. Przegląd Techniczny, 1927, no. 10, pp. 207–212.
- [3] Bryła S.: Wykonanie konstrukcji spawanych. Czasopismo Techniczne, 1930, no. 22, pp. 401–408.
- [4] Augustyn J.: Stefan Bryła: życie i dzieło, Wyd. Fundacja Polskiego Związku Inżynierów Budowlanych „Inżynieria i Budownictwo”, 1994.
- [5] Klimpel A., Melcer M.: Stan aktualny i spawanie naprawcze konstrukcji mostu na rzece Słudwi pod Łowiczem. Przegląd Spawalnictwa, 1998, no. 1, pp. 2–5.
- [6] Nekanda-Trepka L., Ferenc K.: Współtwórcy polskiego spawalnictwa. Przegląd Spawalnictwa, 2000, no. 12, pp. 20–21.
- [7] Beckert M.: Die ersten Schritte der Schweisstechnik in Stahlbau. Schweissen und Schneiden, 2001, no. 10, pp. 701–702.
- [8] Michałowski W. St.: Trzeba myśleć i trzeba pracować. Przegląd Spawalnictwa, 2008, no. 10, pp. 24–25.
- [9] Czapliński K.: Dawne wyroby ze stopów żelaza. Dolnośląskie Wydawnictwo Edukacyjne, Wrocław, 2009.
- [10] Pocica A., Nowak A.: Polskie mosty stalowe. Przegląd Spawalnictwa, 2005, no. 2–3, pp. 24–26.
- [11] Pocica A.: Techniki i technologie spawalnicze na ziemiach polskich do 1939 r. Wydawnictwo Politechniki Opolskiej, Opole, 2015.
- [12] Ambroziak A.: Spawalność stali w konstrukcjach nitowanych. VI Konferencja Naukowo-Techniczna, Problemy i innowacje w remontach energetycznych, Karpacz 26–28.11. 2003, Wyd. OBR Gospodarki Remontowej Energetyki, Wrocław 2003, pp. 15–24.
- [13] Rabięga J.: Pierwsze mosty spawane. Poznań, Politechnika Poznańska, 2019. Archiwum Mostownictwa w Polsce, no. 4.
- [14] Kropacz M., Calik M.: Harmonizacja przepisów prawa w procesie wytwarzania konstrukcji stalowych i aluminiowych. Przegląd Spawalnictwa, 2011, no. 11, pp. 64–67.
- [15] Biegus A.: Projektowanie konstrukcji stalowych wg Eurokodu 3. Część 5. Połączenia spawane, Materiały dydaktyczne. Wydział Budownictwa Lądowego i Wodnego Politechniki Wrocławskiej, Wrocław, 2010.
<http://sigma-not.pl/publikacja-94164-2015-10.html>
- [16] Pękalski G.: Badanie próbki pobranej z balustrady od strony górnej wody mostu drogowego nad kanałem Odry w Brzegu, rok budowy 1920. Instytut Mechaniki Technicznej i Materiałoznawstwa Politechniki Wrocławskiej, Wrocław 2009.